

BOS

homogenisers

MG 45

High-Pressure homogeniser
Model MG45

Pressures up to 600 bar
Capacities up to 25000 l/h



The cylinder block

A single piece precision machined block made out of a high tensile, corrosion resistant, forged stainless steel. Built with front and upper caps giving easy access for inspection and maintenance. The standard design has spring loaded plunger packings with integrated water cooling. The fully sanitary design utilises a minimum of parts and seals and is suitable for C.I.P. Plungers and plunger packings are available in different materials to meet the toughest demands. Generally the cylinder block is executed with high efficient, low noise spherical type pump valves. These valves are spring loaded, suitable for processing viscose and moderate abrasive products. For abrasive products the well known ball type pump valves are available. All these pump valve designs have high wear and corrosion resistant pump valves and field replaceable seats, both made out of Rexalloy®™ or optional seats made of Tungsten Carbide. As an alternative the machine can be executed with conventional 17-4PH poppet type pump valves in combination with Rexalloy®™ seats. There are many other options available to meet specific product or process requirements.

The homogenising valve

Available in a variety of designs and materials, single or two stage, with the standard flat valve and seat in Rexalloy®™ but also with a serrated surface (LW type) or Knife edge for cell rupture applications. Each type specially designed to achieve the highest efficiency with the lowest energy consumption. The different valve designs are available in the standard Rexalloy®™ material, Tungsten Carbide, Ceramic and for some applications with Diamond coating.

The homogenising pressure is hydraulically actuated. The hydraulic system also allows complete automatic control of the homogenising pressures.

The drive end

The one piece high strength cast iron design with integrated gear reduction provides a quiet running machine with low eccentric shaft speeds. The drive has a dry sump with a separate lubrication oil tank and does not require any cooling water. All bearings are pressure lubricated by an electric driven oil pump allowing capacity variation between 15-100% under full load. Both drive shaft and eccentric shaft have oversized roller bearings. The crossheads are designed with adjustable, self aligning ball joint bearings. This unique concept offers unbeatable reliability, requires a minimum of maintenance and down time.

Two stage homogenising valve

A typical two stage hydraulic operated homogenising valve assembly with a plug type valve in the first stage and a pilot type valve in the second stage.

This assembly meets the highest demand for C.I.P. cleaning, is easily accessible for maintenance and uses a minimum of parts.

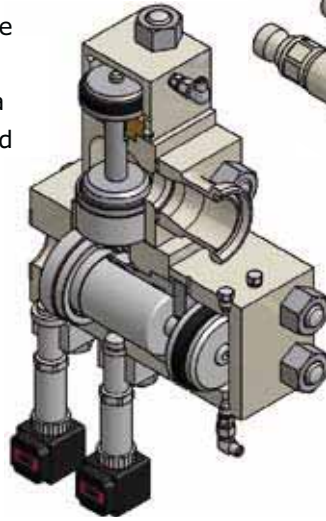

Cylinder block

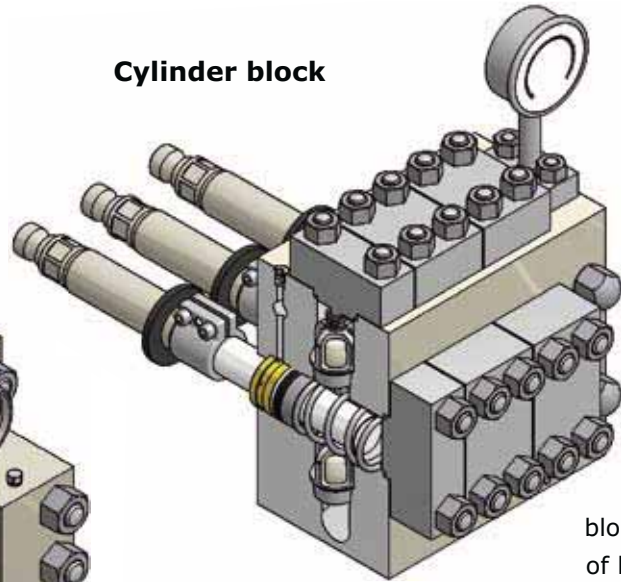

The pump block is a one piece precision machined block, made out of high strength corrosion resistant forged stainless steel. The one piece design utilises a minimum of parts and seals, is fully sanitary and suitable for C.I.P.

MG45 CAPACITY RANGE						
Operating pressure	SPHERICAL type pump valves for viscose and moderatly abrasive products		POPPET TYPE pump valves for low-viscosity and moderately abrasive products		BALL TYPE pump valves for high-viscosity and abrasive products and products containing solids	
	Maximum capacity	Eccentric shaft speed	Maximum capacity	Eccentric shaft speed	Maximum capacity	Eccentric shaft speed
600 bar	6000 l/h	144 rpm			5500 l/h	136 rpm
550 bar	7000 l/h	157 rpm	6500 l/h	147 rpm	6000 l/h	139 rpm
500 bar	8000 l/h	164 rpm	7500 l/h	156 rpm	6600 l/h	140 rpm
450 bar	9000 l/h	165 rpm	8500 l/h	158 rpm	7500 l/h	142 rpm
400 bar	10000 l/h	162 rpm	9500 l/h	156 rpm	8500 l/h	142 rpm
350 bar	11500 l/h	167 rpm	11000 l/h	161 rpm	9500 l/h	142 rpm
300 bar	12800 l/h	167 rpm	12000 l/h	158 rpm	10600 l/h	142 rpm
250 bar	15500 l/h	165 rpm	14500 l/h	156 rpm	12800 l/h	141 rpm
200 bar	20000 l/h	163 rpm	18500 l/h	152 rpm	16500 l/h	139 rpm
150 bar	25000 l/h	150 rpm	24000 l/h	145 rpm	22000 l/h	136 rpm

Weight 5000 kg

